

# CHAIN-GE IS COMING TO ROTARY GATE SYSTEMS!

## MODEL SL-CD VEHICULAR CHAIN DRIVE OPERATOR

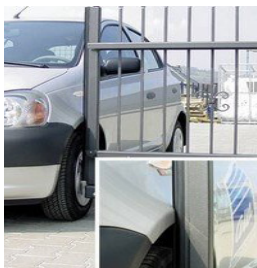

**UL325 MONITORED OBSTRUCTION  
INPUTS TO PREVENT ENTRAPMENT  
OR GATE CLOSING ON PEOPLE/  
PROPERTY**



**BUILT IN BATTERY BACKUP LONG  
USE AFTER POWER FAILURE\***

**NUMBER OF CYCLES AND TIME OF USE ON BATTERY  
POWER DEPENDS ON MANY FACTORS, INCLUDING SIZE  
AND WEIGHT OF GATE, ACCESSORIES, ETC.**



**CONVENIENT, LOCKABLE MANUAL  
RELEASE FOR MULTIPLE OPEN  
OPTIONS IF YOU LOSE POWER**



- MOUNTING POINTS ARE THE SAME AS THE POPULAR SL-RD RACK AND PINION SLIDE GATE OPERATOR
- CONVENIENT LOCKING MANUAL RELEASE FOR OPENING, NEVER GET LOCKED IN OR OUT OF YOUR PROPERTY
- INDUSTRY STANDARD #40 CHAIN
- 3D PRINTED REVERSIBLE CHAIN GUARD FOR EASE OF USE ON SITE
- PERMANENT MAGNET DC MOTOR FOR PROVIDES AMPLE TORQUE FOR ANY APPLICATION

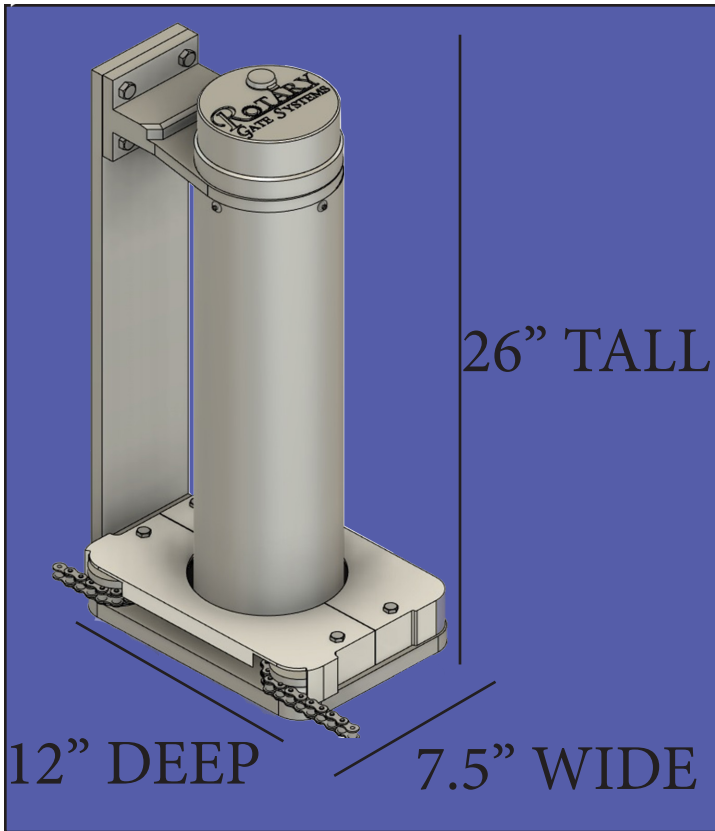

## MECHANICAL

BODY: BILLET ALUMINUM, POWDER-COATED FOR ADDITIONAL CORROSION RESISTANCE

CHAIN GUARD: 3D PRINTED PET-G FOR HEAT AND UV RESISTANCE

SPEED: APPROXIMATELY 12"/SEC

CHAIN: UNIT IS SHIPPED WITH 20FT (6M) OF #40 ROLLER CHAIN

## ELECTRICAL

AUTOMATIC LIMIT LEARNING AND SOFT START/STOP TUNING

AUTO-CLOSE TIMER 1-99 SEC

BUILT IN ON/OFF SWITCH

BUILT IN ALARM AND RESET SWITCH

PROGRAMMING THROUGH DISPLAY

PARTIAL-OPEN AND ANTI-TAILGATING FEATURES

115VAC OUTLET AVAILABLE FOR ACCESSORIES

AUTOMATIC FAIL SAFE OPEN ON POWER LOSS (CAN BE PROGRAMMED FOR OTHER OPTIONS)

PORTS FOR PLUG-IN LOOP DETECTORS (OPEN, REVERSE, SHADOW)

## PERFORMANCE

SL-C-CD:  
40' opening  
1,700lb gate

SL-I-CD:  
50' opening  
2,700lb gate

## MISCELLANEOUS

SHIPPING WEIGHT: TWO BOXES  
APPROXIMATELY 45LBS (20.5KG)

OPERATOR REQUIRES MONITORED TYPE B1 AND/OR TYPE B2 ENTRAPMENT PROTECTION DEVICES

ROTARY IQ AVAILABLE FOR REMOTE MONITORING, PROGRAMMING, AND CUSTOMER ACCESS CONTROL.